

PARTS LIST		
ITEM	QTY	PART NAME
1	2	SUPPORT
2	1	GUIDE ROD
3	1	LEAD SCREW
4	2	LEAD SCREW COLLAR
5	2	ROLL PIN
6	1	RIGHT THREAD INSERT
7	2	INSERT SCREW
8	1	HANDLE ATTACHMENT
9	1	LEFT THREAD EXTENSION
10	1	RIGHT GUIDE EXTENSION
11	1	HANDLE (1)

TOLERANCES
 Hole spacings: ± 0.005
 Hole diameters: $+0.01$
 -0.0
 All others: ± 0.01 unless
 otherwise stated

Team Two Times Four

TITLE

Adjustment system

UNITS	SIZE
INCH	A

DRAWN

Steven Siewert 2024-03-02

SCALE 1:1.5

SHEET 1/5

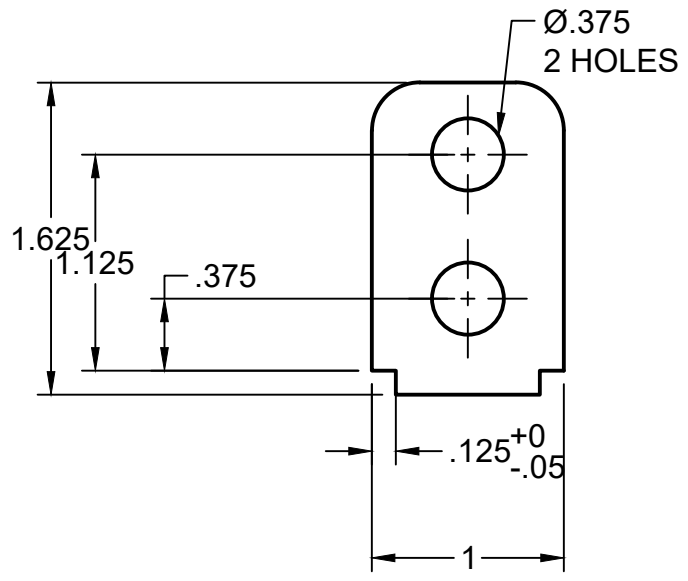

ITEM 1 - SUPPORT

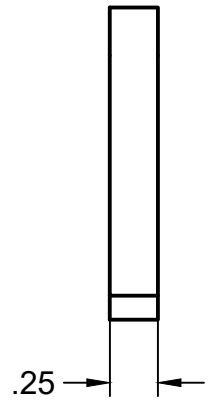

ITEM 2 - GUIDE ROD

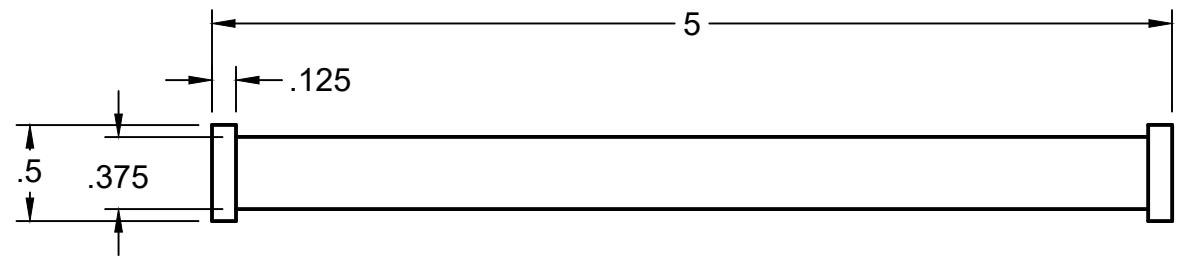
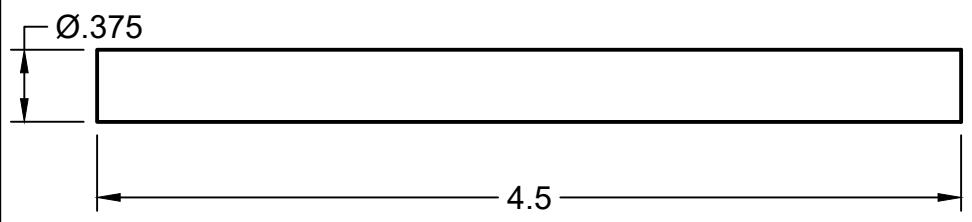

ITEM 3 - HANDLE

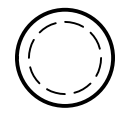

TOLERANCES
 Hole spacings: ± 0.005
 Hole diameters: $+0.01$
 -0.0
 All others: ± 0.01 unless
 otherwise stated

Team Two Times Four

TITLE		UNITS	SIZE
Adjustment system		INCH	A

DRAWN	Steven Siewert 2024-03-02	SCALE 1:1	SHEET 2/5
-------	---------------------------	-----------	-----------

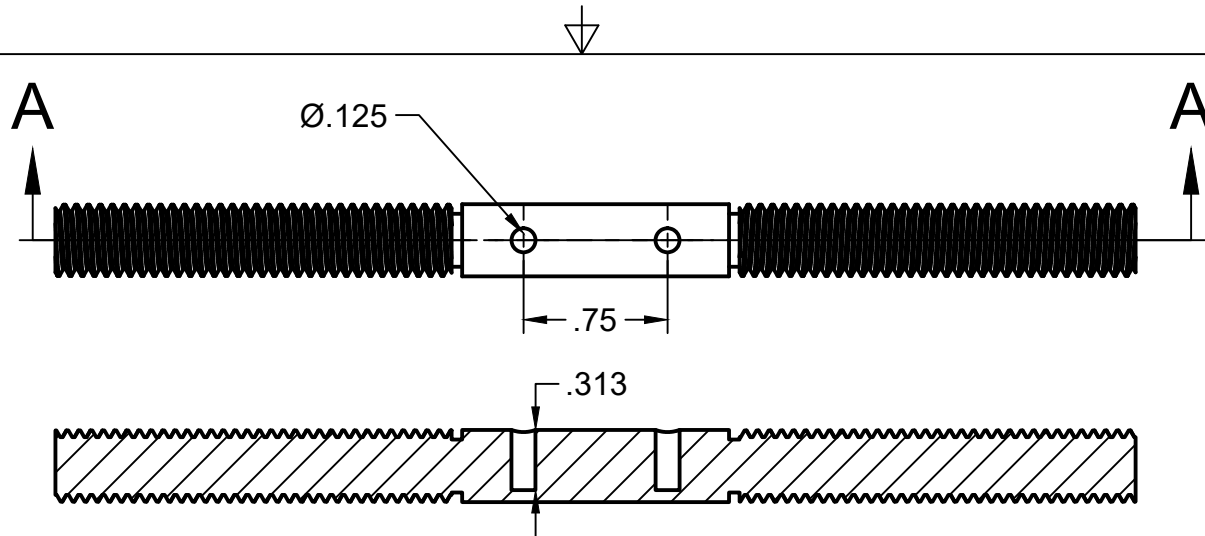

SECTION A-A

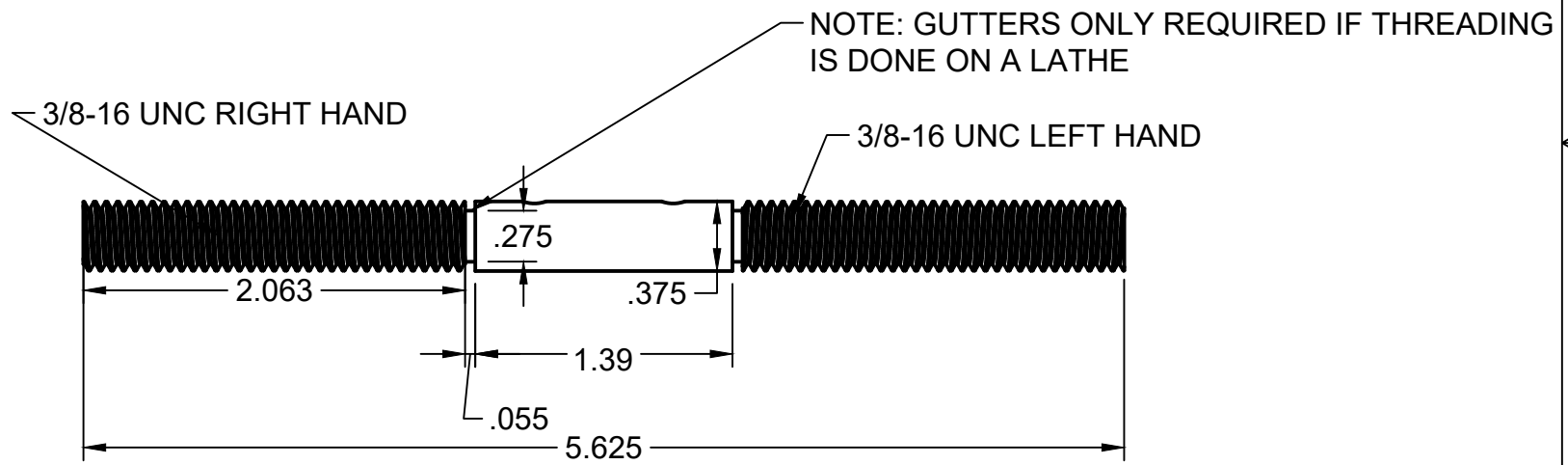

ITEM 4 - LEAD SCREW

<p>TOLERANCES Hole spacings: ± 0.005 Hole diameters: $+0.01$ -0.0 All others: ± 0.01 unless otherwise stated</p>	<p>Team Two Times Four</p>			
	<p>TITLE Adjustment system</p>		<p>UNITS INCH</p>	<p>SIZE A</p>
	<p>DRAWN Steven Siewert 2024-03-02</p>	<p>SCALE 1:1</p>	<p>SHEET 3/5</p>	

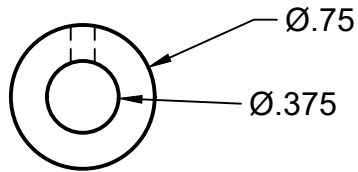
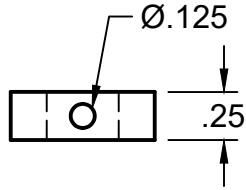

ITEM 5 - LEAD SCREW COLLAR

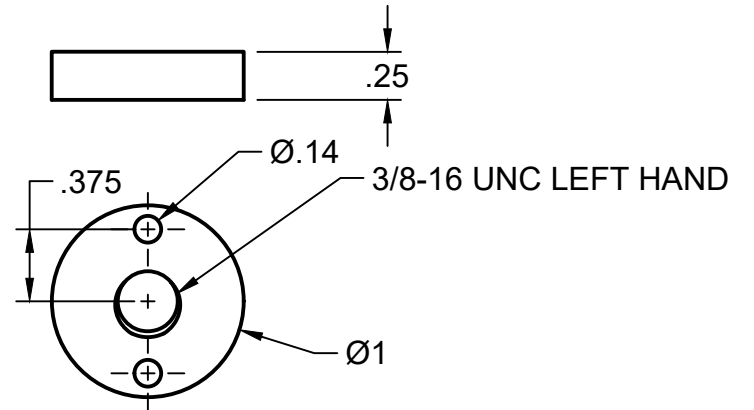

ITEM 7 - RIGHT THREAD INSERT

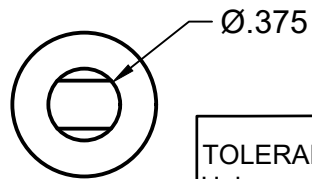
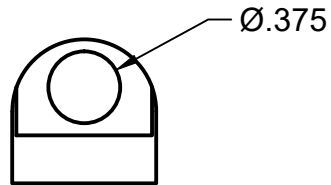
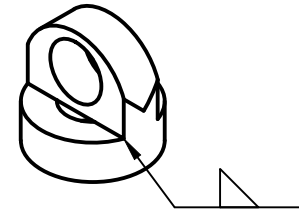
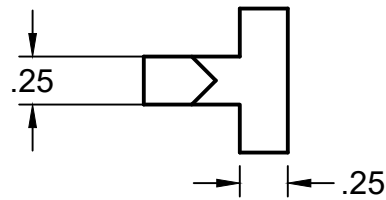
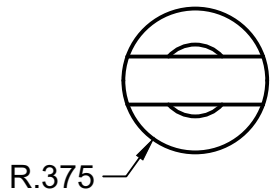

ITEM 9 - HANDLE ATTACHMENT

TOLERANCES
 Hole spacings: ±0.005
 Hole diameters: +0.01
 -0.0
 All others: ±0.01 unless
 otherwise stated

Team Two Times Four

TITLE

Adjustment system

UNITS
 INCH

SIZE
 A

DRAWN

Steven Siewert 2024-03-02

SCALE 1:1

SHEET 4/5

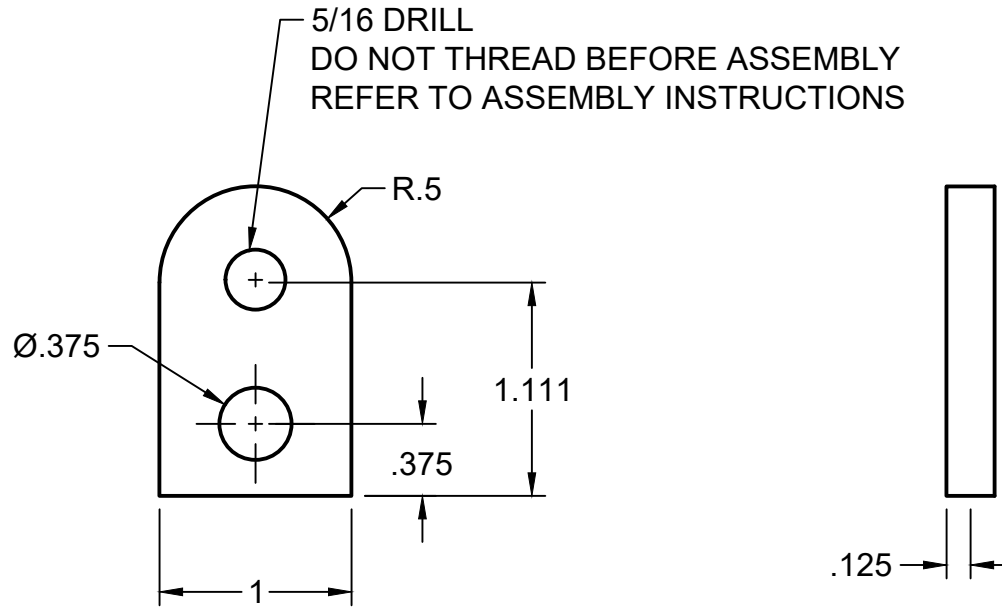

ITEM 14 - LEFT THREAD EXTENSION

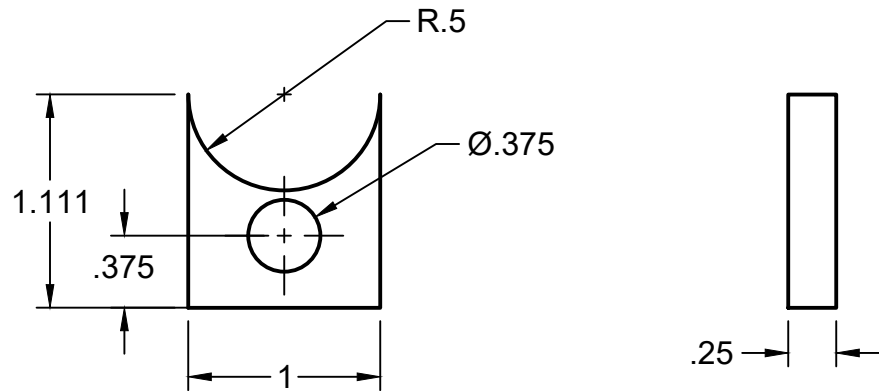

ITEM 15 - RIGHT GUIDE EXTENSION

TOLERANCES
Hole spacings: ±0.005
Hole diameters: +0.01
-0.0
All others: ±0.01 unless
otherwise stated

Team Two Times Four

TITLE

Adjustment system

UNITS	SIZE
INCH	A

DRAWN

Steven Siewert 2024-03-02

SCALE 1:1

SHEET 5/5