

8

7

6

5

4

3

2

1

REVISIONS				
ZONE	REV.	DESCRIPTION	DATE	APPROVED

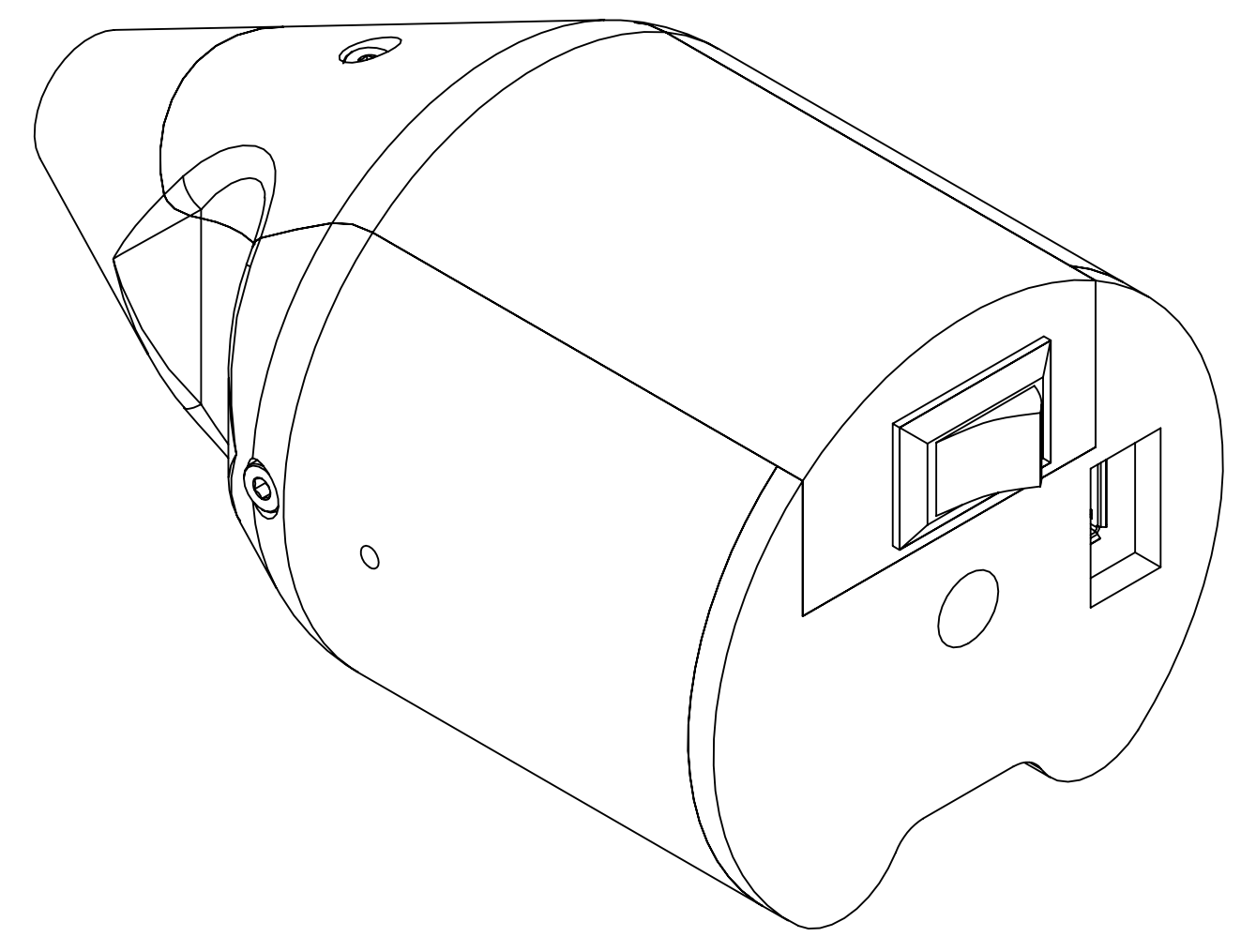
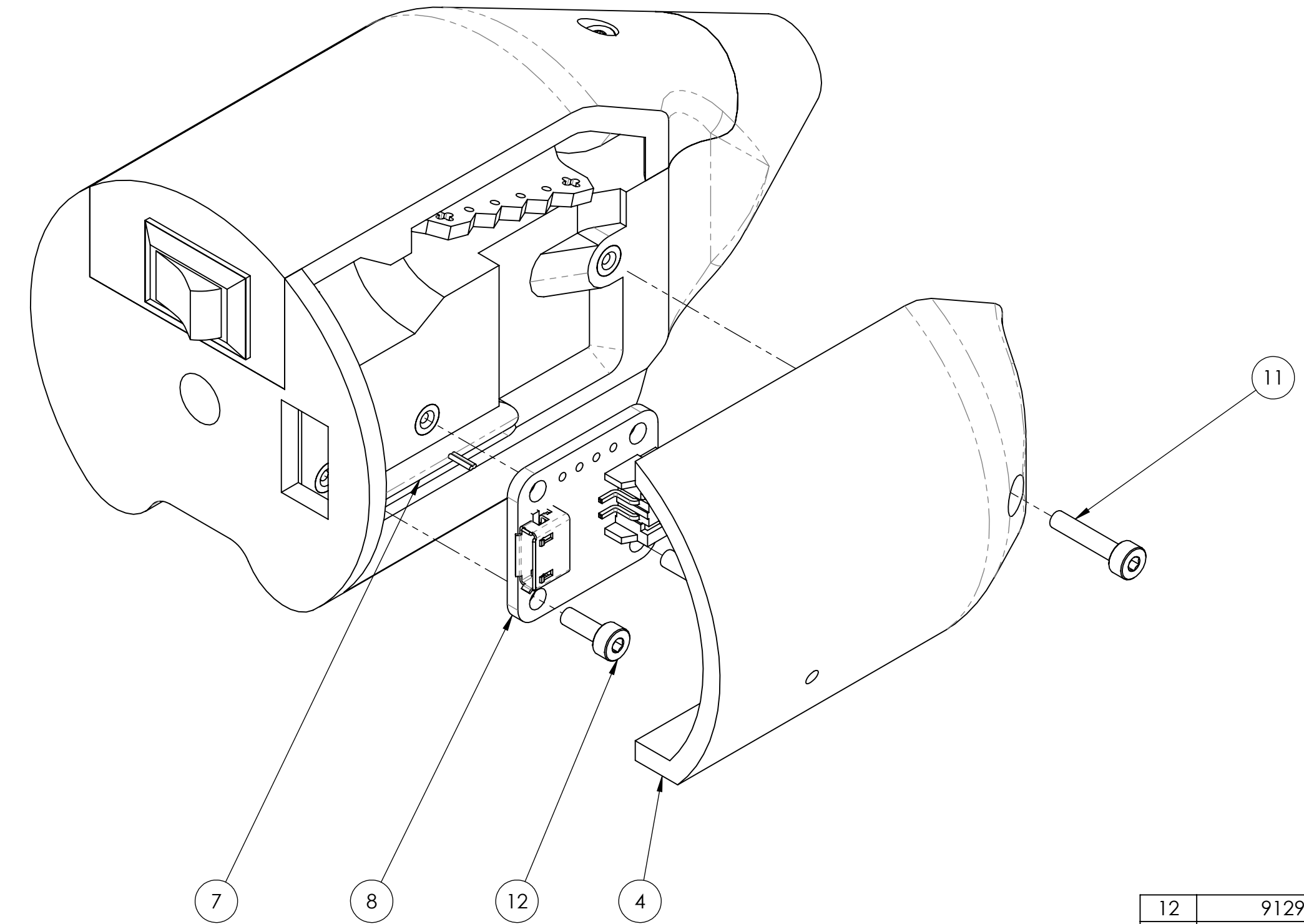
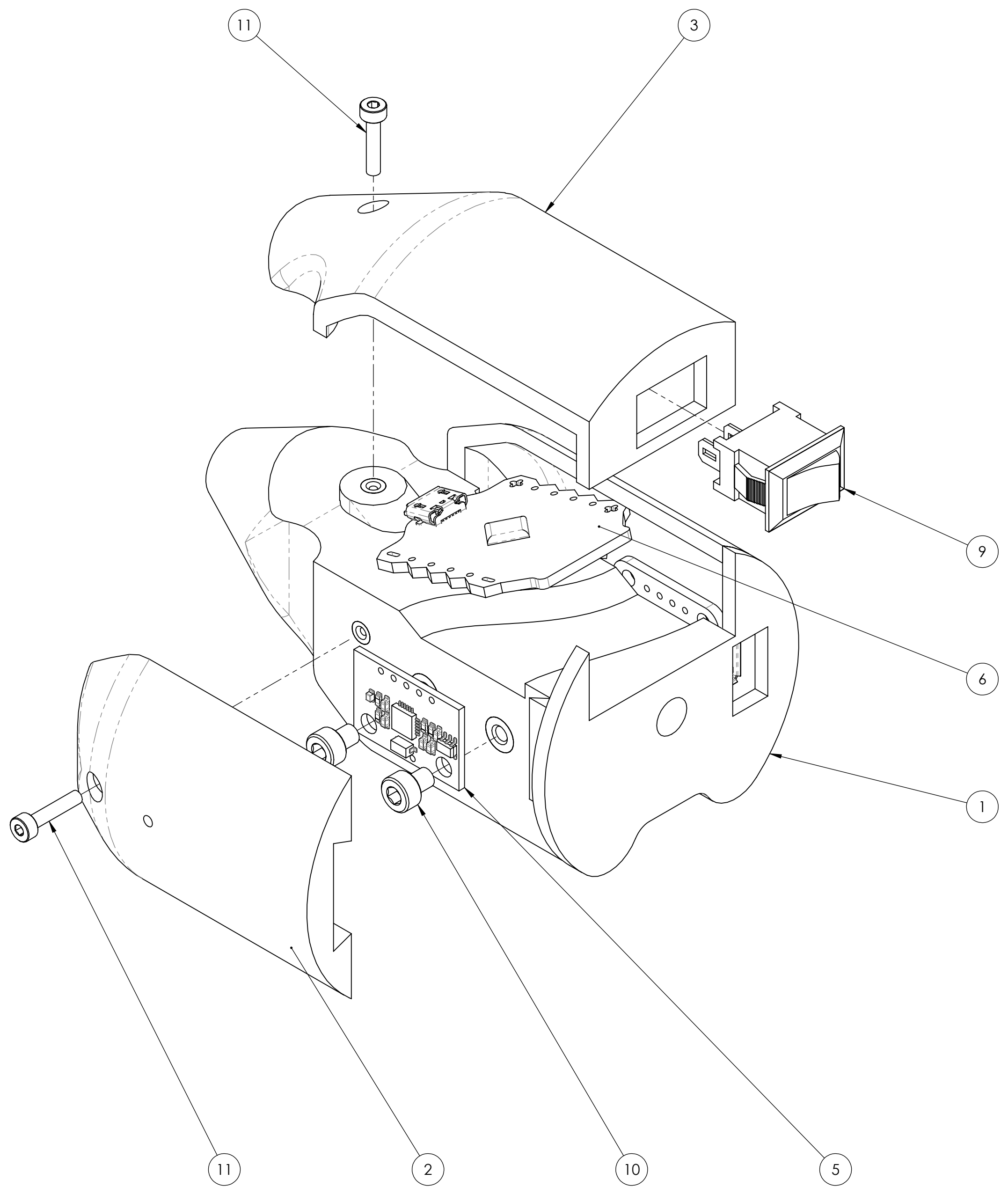

ITEM	DRAWING NUMBER	DESCRIPTION	QTY
12	91292A831	M2X0.4 X 6mm SSTEEL SCKT HD SCW (MCMMASTER-CARR)	2
11	91292A833	M2X0.4 X 10mm SSTEEL SCKT HD SCW (MCMMASTER-CARR)	3
10	93705A811	M3x0.5 x 4mm SOCKET HEAD SCW (MCMMASTER-CARR)	2
9	PRK22J5DBBNN	MINIATURE ROCKER SWITCH (ZF ELECTRONICS)	1
8	1904	MICRO LIPO CHARGER MODULE (ADAFRUIT)	1
7	LP402025	3.7V 150mAh LITHIUM POLYMER CELL BATTERY (PK CELL)	1
6	DFR0339	BLE SINGLE CHIP COMBUTER (DF ROBOT)	1
5	SEN0142	6 DOF ACCELEROMETER GYROSCOPE (DF ROBOT)	1
4	FMS-GT-PRT-04	COVER	1
3	FMS-GT-PRT-03	COVER	1
2	FMS-GT-PRT-02	COVER	1
1	FMS-GT-ASM-01	CENTRE BODY ASSY	1

PARTS LIST / BILL OF MATERIALS

UNLESS OTHERWISE SPECIFIED: DIM'S ARE IN MILLIMETERS TOLERANCE ON ANGLES 0.5° 0 PLACE DECIMAL ± 0.5mm 1 PLACE DECIMAL ± 0.25mm 2 PLACE DECIMAL ± 0.13mm BREAK ALL SHARP EDGES 25-50mm INTERPRET THIS DRAWING IN ACCORDANCE WITH: ASME Y14.5-2018		NAME S.TREMBLAY	DATE 5/19/2021	<p>GENERAL ASSY</p> <p>GYRO TRACE</p>
DRAWN	CHECKED	Q.A.	MATERIAL	
WFG APPR.				MATL. SPEC. SURFACE TEXTURE HEAT TREAT <input checked="" type="checkbox"/>
DO NOT SCALE DRAWING	FINISH			SIZE DWG. NO. REV D FMS-GT-ASM-00 - SCALE: 2:1 WEIGHT: 98[g] SHEET 1 OF 1

4

3

2

1

NOTES:

1. PRESS HEAT SET INSERTS (ITEMS 2 AND 3) AS SHOWN, PER MANUFACTURER'S INSTRUCTIONS

REVISIONS				
ZONE	REV.	DESCRIPTION	DATE	APPROVED

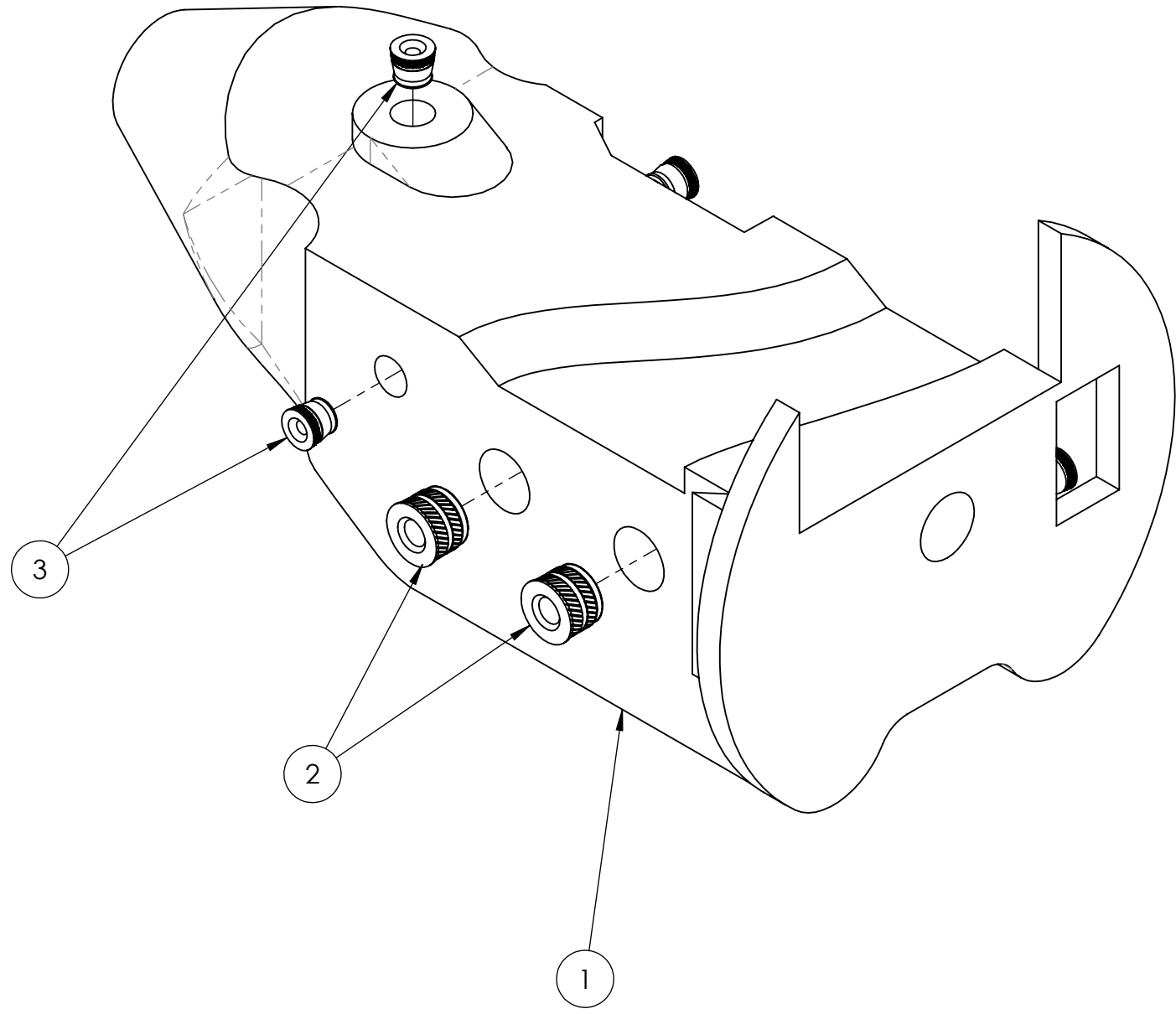
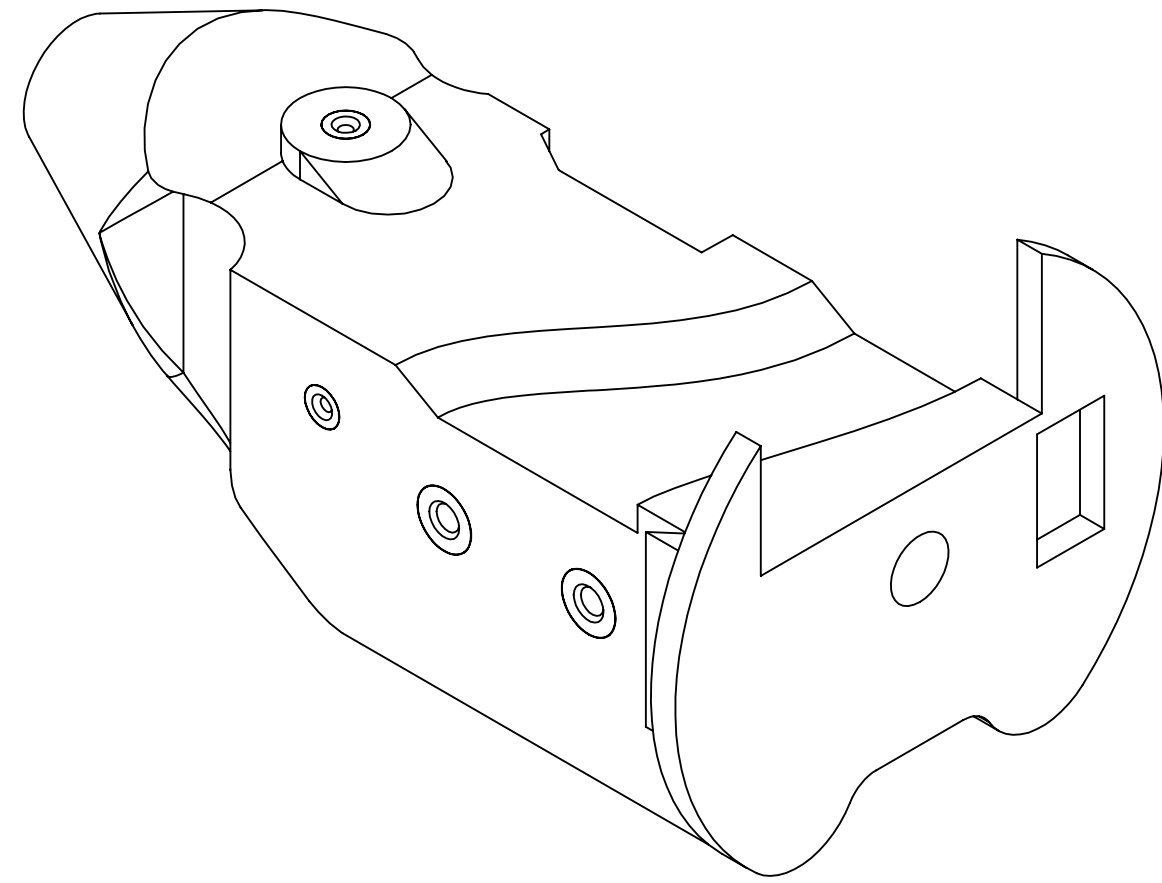
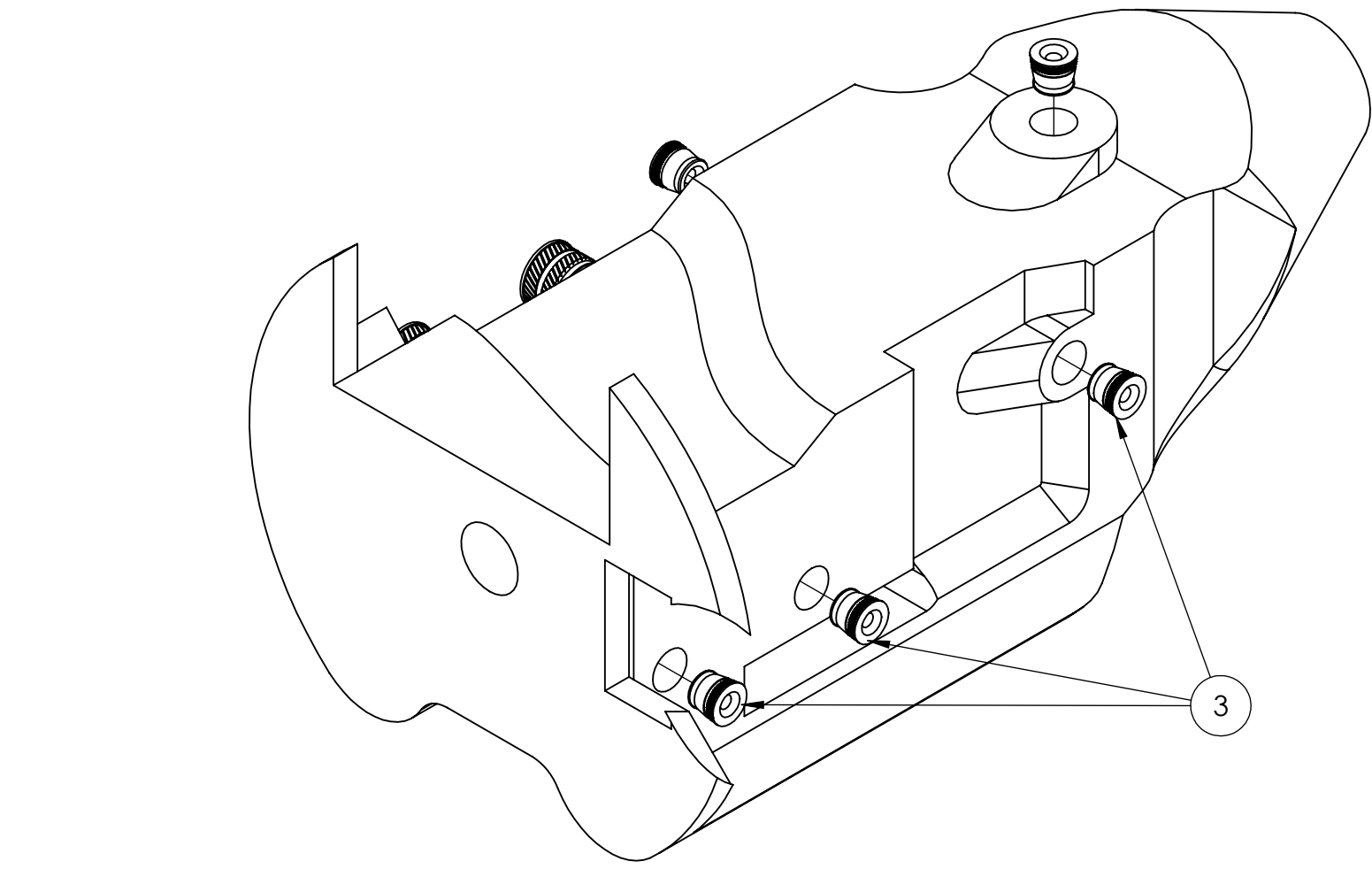

ITEM	DRAWING NUMBER	DESCRIPTION	QTY
3	94180A307	M2X0.4 BRONZE HEAT SET INSERT (MCMaster-CARR)	5
2	94180A331	M3X0.5 BRONZE HEAT SET INSERT (MCMaster-CARR)	2
1	FMS-GT-PRT-01	CENTRE BODY	1

PARTS LIST / BILL OF MATERIALS

UNLESS OTHERWISE SPECIFIED:		NAME	DATE	CGEC CEED
DIMS. ARE IN MILLIMETERS TOLERANCE ON ANGLES 0.5° 0 PLACE DECIMAL ± 0.5mm 1 PLACE DECIMAL ± 0.25mm 2 PLACE DECIMAL ± 0.13mm BREAK ALL SHARP EDGES .25-.50mm		S.TREMBLAY	5/19/2021	
INTERPRET THIS DRAWING IN ACCORDANCE WITH: ASME Y14.5-2018		DRAWN	CHECKED	CENTRE BODY ASSY GENERAL ASSY GYRO TRACE
DO NOT SCALE DRAWING		MFG APPR.	Q.A.	
MATERIAL		SURFACE TEXTURE		SIZE DWG. NO.
MATERIAL SPEC.		HEAT TREAT		C FMS-GT-ASM-01
FINISH		SCALE: 2:1		REV -
		WEIGHT: 0.14[g]		SHEET 1 OF 1

4

3

2

1