

NOTE: ALL HOLES IN THIS SYSTEM ARE 9/64

PARTS LIST			
ITEM	QTY	PART NUMBER	MATERIAL
1	1	BACKER PLATE	STEEL
2	2	BOTTOM SURFACE A	PLA
3	2	BOTTOM SURFACE B	PLA
4	10	6-32 SCREW	STEEL

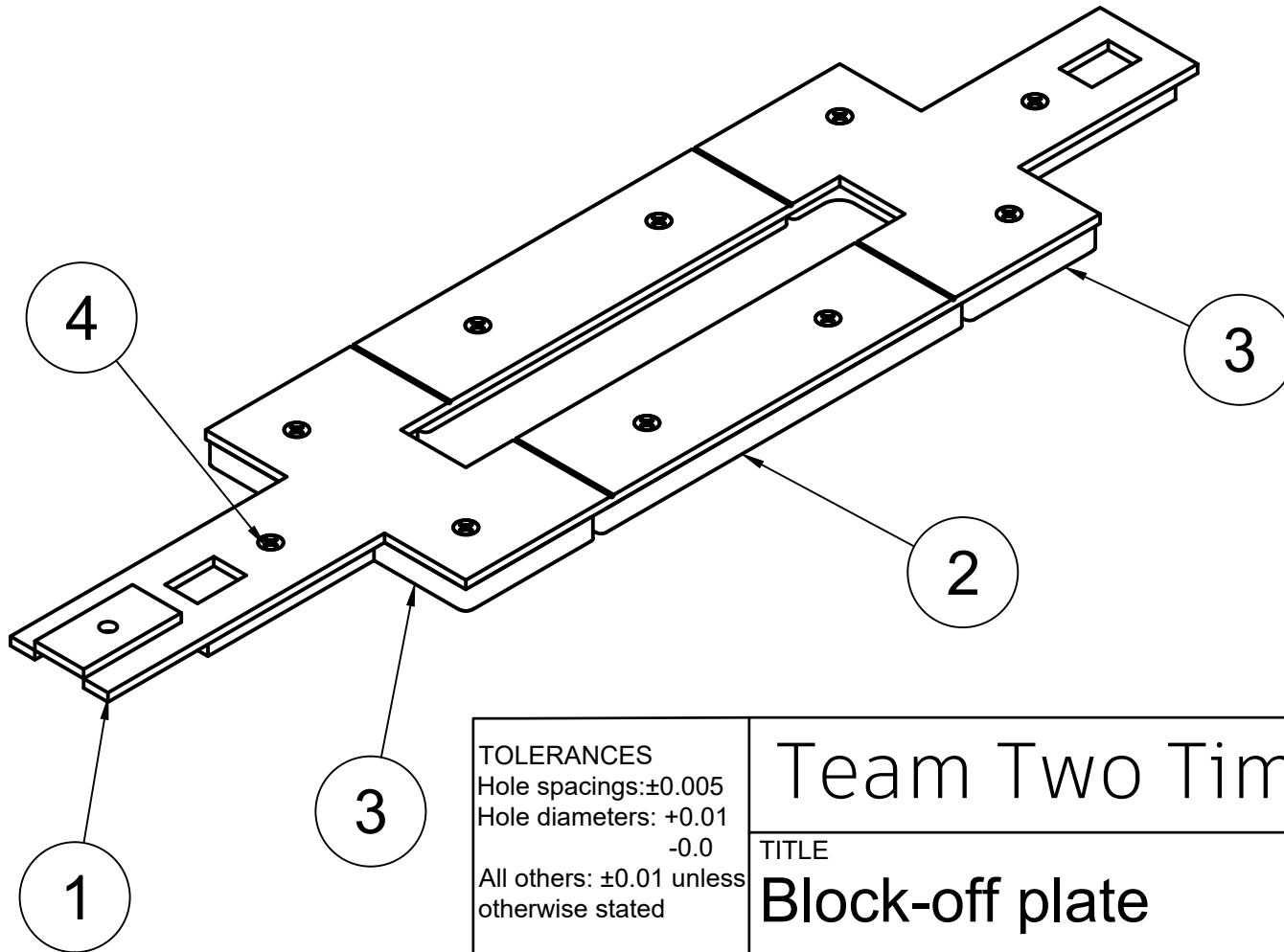

<p>TOLERANCES</p> <p>Hole spacings: ± 0.005</p> <p>Hole diameters: $+0.01$ -0.0</p> <p>All others: ± 0.01 unless otherwise stated</p>	<p>Team Two Times Four</p>			
	<p>TITLE</p> <p>Block-off plate</p>		<p>UNITS</p> <p>INCH</p>	<p>SIZE</p> <p>A</p>
	<p>DRAWN</p> <p>Steven Siewert</p>	<p>2024-03-24</p>	<p>SCALE 1:8</p>	<p>SHEET 1/3</p>

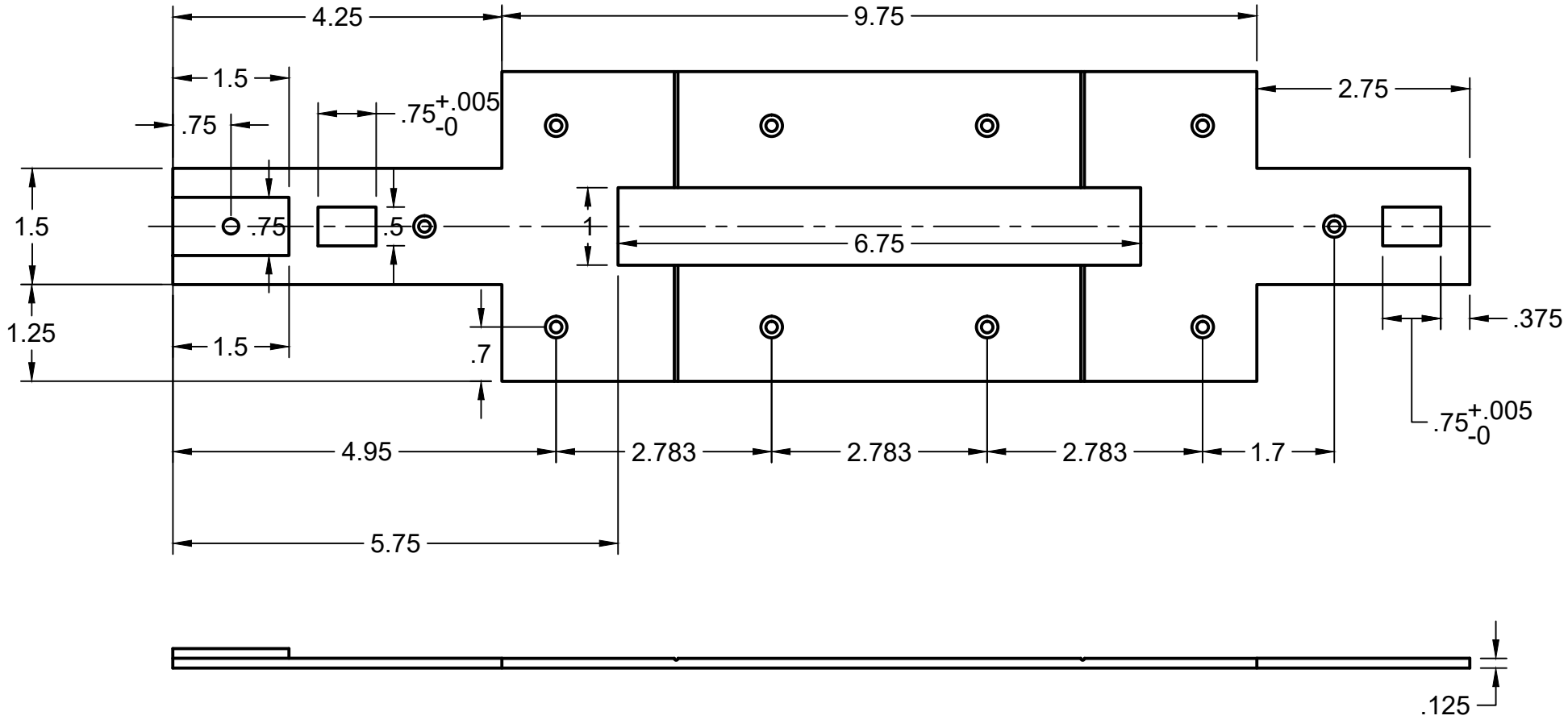

TOLERANCES
 Hole spacings: ±0.005
 Hole diameters: +0.01
 -0.0
 All others: ±0.01 unless
 otherwise stated

Team Two Times Four

TITLE		UNITS	SIZE
Block-off plate		INCH	A

DRAWN	Steven Siewert 2024-03-24	SCALE 1:2	SHEET 2/3
-------	---------------------------	-----------	-----------





NOTE: THE SIDE CLOSER TO THE HOLES INSTALLS ON THE INSIDE

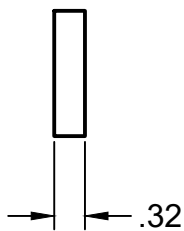
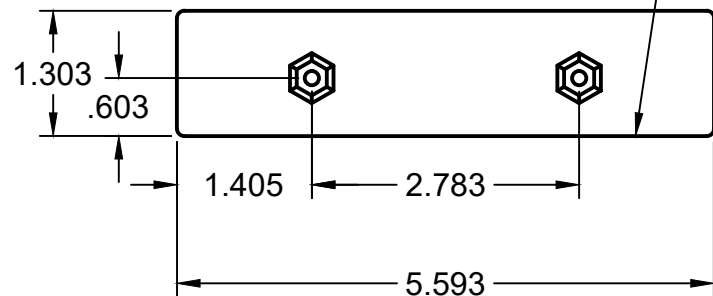

BOTTOM SURFACE A

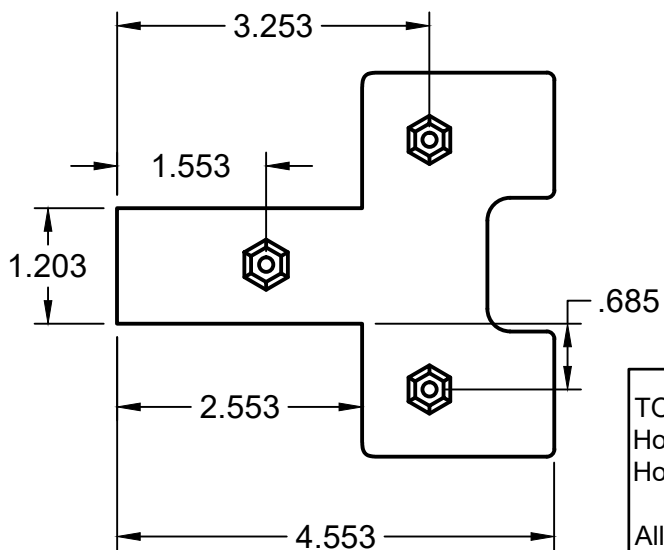

BOTTOM SURFACE B

TOLERANCES
 Hole spacings: ± 0.005
 Hole diameters: $+0.01$
 -0.0
 All others: ± 0.01 unless
 otherwise stated

Team Two Times Four

TITLE

Block-off plate

UNITS
INCH

SIZE
A

DRAWN

Steven Siewert 2024-03-24

SCALE 1:2

SHEET 3/3

